

# Ferrite Cores for EMI Suppression

## Ferrite Beads

### B Series(Lead)

B series are easy to handle and are supplied in various materials, shapes and packaging styles to meet for users' requests.

#### FEATURES

- Appropriate materials and shapes can be selected from various cores to suppress EMI effectively.
- The axial leaded type can be supplied both box and reel type packagings with 52mm[2.047 inches] and 26mm [1.024 inches] tape width (26mm for the box packaging). So can be selected depending on your automatic insertion machines.

#### APPLICATIONS

Video, acoustic, office automation equipment, communication equipment, automotive electronic equipment and others.

- Absorption EMI and penetrating noise
- Prevent parasitic oscillation

#### PRODUCT IDENTIFICATION

HF55	B	TL	3.5	X	4.5	B	-AG
(1)	(2)	(3)	(4)		(5)	(6)	(7)

(1) Material code

(2) Series

(3) Type

TL: Taping type, 52mm[2.047 inches] tape width

TS: Taping type, 26mm[1.024 inches] tape width

(4) Outer diameter  $\varnothing A$ (mm)

(5) Length B(mm)

(6) Packaging style

B: Ammo-pack

R: Reel

(7)  $\varnothing 0.62$ mm Sn-plated soft copper wire(lead free)

#### MATERIAL CHARACTERISTICS

Material	Initial permeability $\mu_i$	Temperature factor of initial permeability $\alpha_{\text{pir}} \times 10^{-6}/^\circ\text{C}$	Curie temperature $T_c$ ( $^\circ\text{C}$ )	Saturation magnetic flux density $B_s$ (mT)
HF70	1500	1 to 6	>100	280[H=1600A/m]
HF55	550	15 to 35	>125	290[H=1600A/m]

#### PACKAGING STYLE AND QUANTITIES

##### REEL

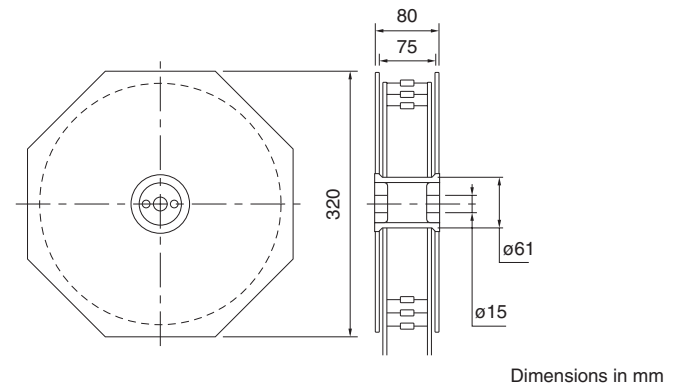

Packaging	Wrapping	Quantity/box
Taping	Reel	4000 pieces/reel

##### BOX

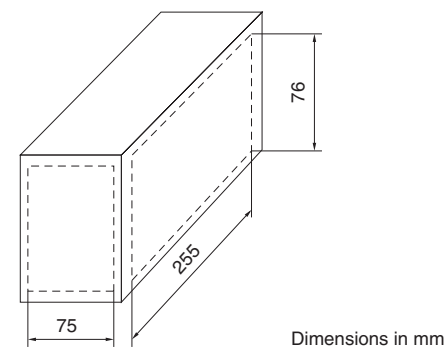

Packaging	Wrapping	Quantity/box
Taping	Box	1500 pieces/box

## SHAPES AND DIMENSIONS/ELECTRICAL CHARACTERISTICS

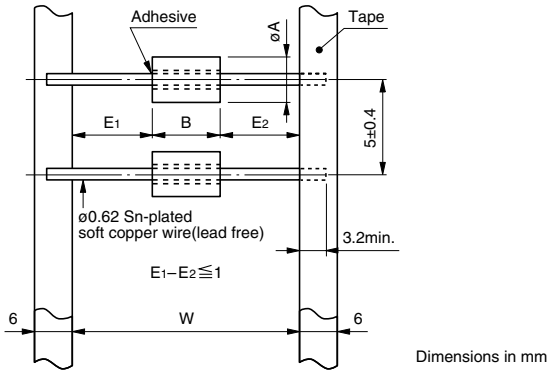

Part No.	Dimensions(mm)			Impedance( $\Omega$ )[at 23°C]	
	A	B	W	10MHz typ.	100MHz typ.
HF55BTL3.5X4.5B-AG	3.5±0.2	4.5±0.4	52+2/-1	34	74
HF55BTL3.5X4.5R-AG	3.5±0.2	4.5±0.4	52+2/-1	34	74
HF70BTL3.5X6R-AG	3.5±0.2	6±0.4	52+2/-1	50	83
HF55BTL3.5X8R-AG	3.5±0.2	8±0.4	52+2/-1	58	125
HF70BTL3.5X9R-AG	3.5±0.2	9±0.4	52+2/-1	76	120
HF55BTS3.5X4.5B-AG	3.5±0.2	4.5±0.4	26+1.5/-0	34	74

## TYPICAL ELECTRICAL CHARACTERISTICS

### IMPEDANCE vs. FREQUENCY CHARACTERISTICS

#### HF55BTL3.5X4.5□-AG

#### HF70BTL3.5X6R-AG

#### HF55BTL3.5X8R-AG

#### HF70BTL3.5X9R-AG

#### HF55BTS3.5X4.5B-AG

